

**inoven**  
Innovative Oven Technologies

# PRODUCT INFORMATION



**Artos 5+2**  
MULTIPURPOSE OVEN

**PRODUCT CODE:** AYF - 5+2 E



# Artos 5+2

## **Rotary and Deck Oven in one unity.**

Our multipurpose oven series brings together rotary and deck oven in a single unit, providing users with a wide range of baking options for all types of products. Since each oven Artos contains works independently of the others, you can bake different products simultaneously and keep your product range at a fairly wide level.

Artos, with its interior dimensions of 60x80 cm, is a highly suitable option for small businesses with limited baking space. Thanks to its modular design, you can separate the rotary oven from the deck oven and place it in another location for usage when needed. In the future stages of your business, you can add one more deck oven to Artos, increasing your production capacity by 25%.

Artos possesses versatile and long-lasting characteristics due to its consistent and balanced baking performance, housing two different oven systems in a single unit, and the ability to increase its capacity as needed.

# Airtos 5000+2



## PRODUCT FEATURES

- Autostart
- Max Oven Degree 300 °C
- Hood with extractor fan
- Cooling System (Rotary Oven)
- Manual klappe system (Deck Oven)
- Manual and automatic steam system
- Strong insulation and energy saving
- High temperature resistant door gasket
- Heat resistant baking stone (Deck Oven)
- High temperature resistant lockable wheel
- Protection relay against voltage fluctuations.
- 100 recordable programs with 5 steps in each.
- Tempered double door glass, easy to dismantle and clean.
- In each deck top and bottom degree can be adjusted with differently for sensitive baking



## PRODUCT DETAILS

Code	Pan Capacity	Rotary Oven Pan Distance	Width	Depth	Total Height	Deck Oven Inner Dimensions	Weight	Electrical Connection	Oven Power	Deck Oven Steam Power	Total Power
AYF - 5+2 E	40x60 cm Pan 5 pcs in Rotary Oven 2 pcs in Deck Oven	8 cm	105 cm	129 cm	190 cm	60x80x19 cm	340 kg	380 V - 50 Hz - 3 PH	9 kW Rotary Oven 7 kW Deck Oven	2,5 kW	18,5 kW

# PROPER PRODUCT PLACING

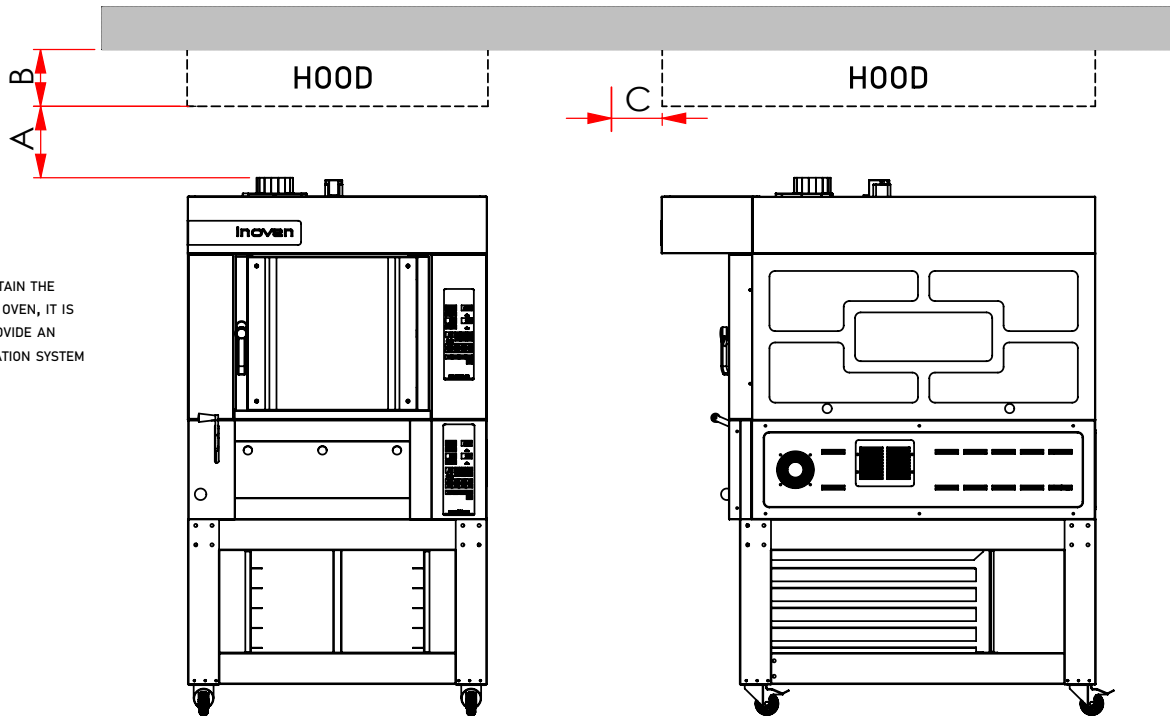

- IN ORDER TO MAINTAIN THE LONGEVITY OF THE OVEN, IT IS NECESSARY TO PROVIDE AN ADEQUATE VENTILATION SYSTEM
- REQUIRED HOOD PULL POWER 800 m<sup>3</sup>/h

HOOD DESIGNS MAY DIFFER AS LONG AS THEY DO NOT EXCEED THE MEASUREMENT RANGES SPECIFIED IN THE VENTILATION

SIZE	A	B	C
VALUE	Min 190 mm Max 410 mm	Min 200 mm	Max 300 mm

FOR LONGEVITY AND EFFICIENT PERFORMANCE, THE MINIMUM DISTANCES SPECIFIED IN THE DIAGRAM BELOW MUST BE MAINTAINED AROUND THE PRODUCT

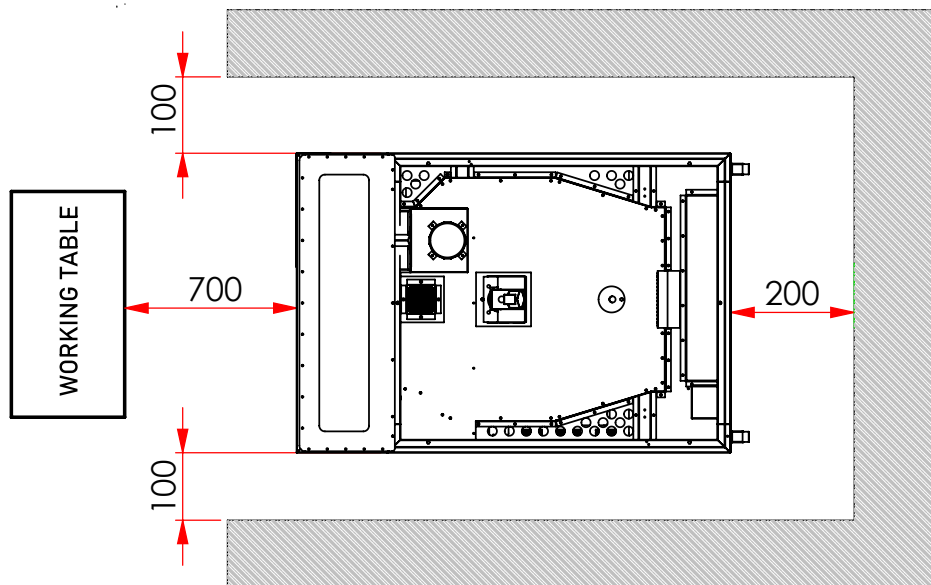

# PRODUCT DIMENSIONS

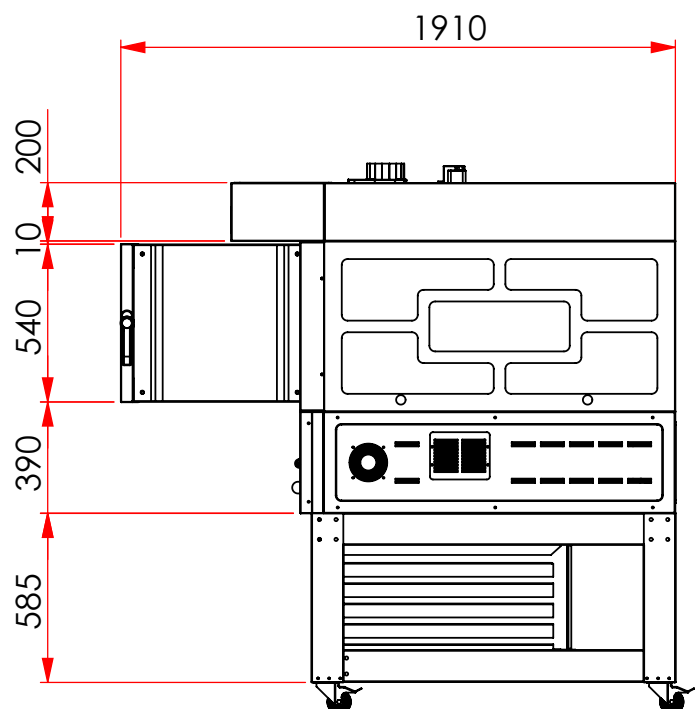
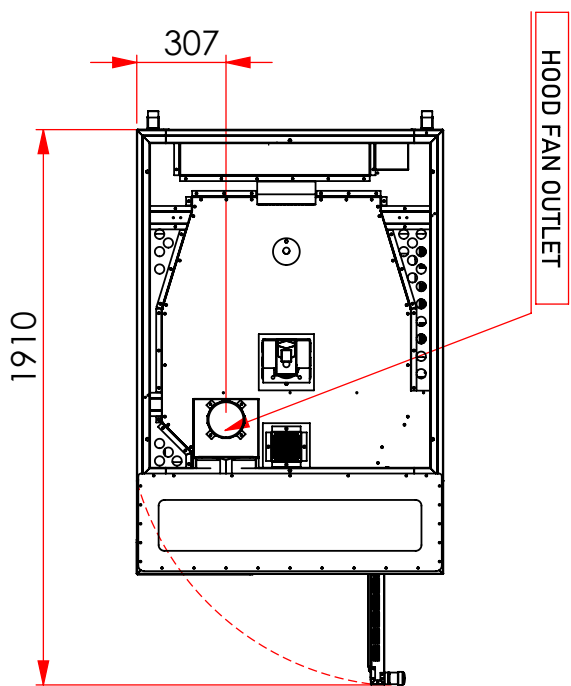
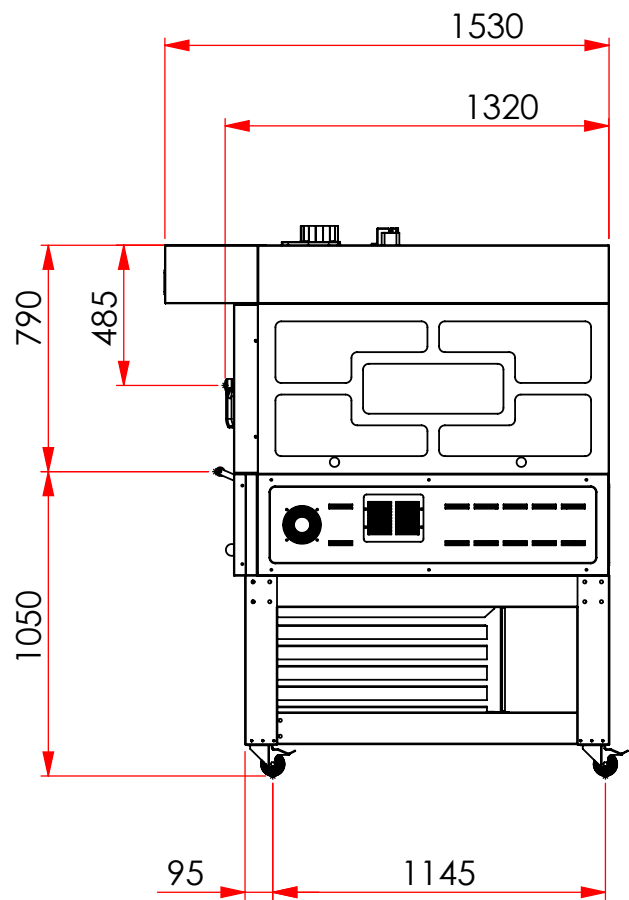
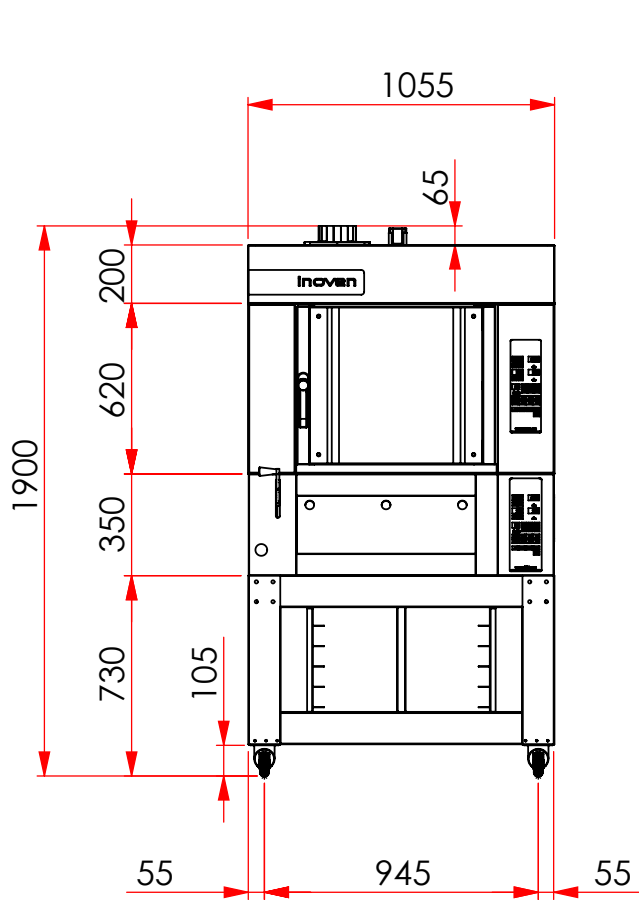

# INSTALLATION

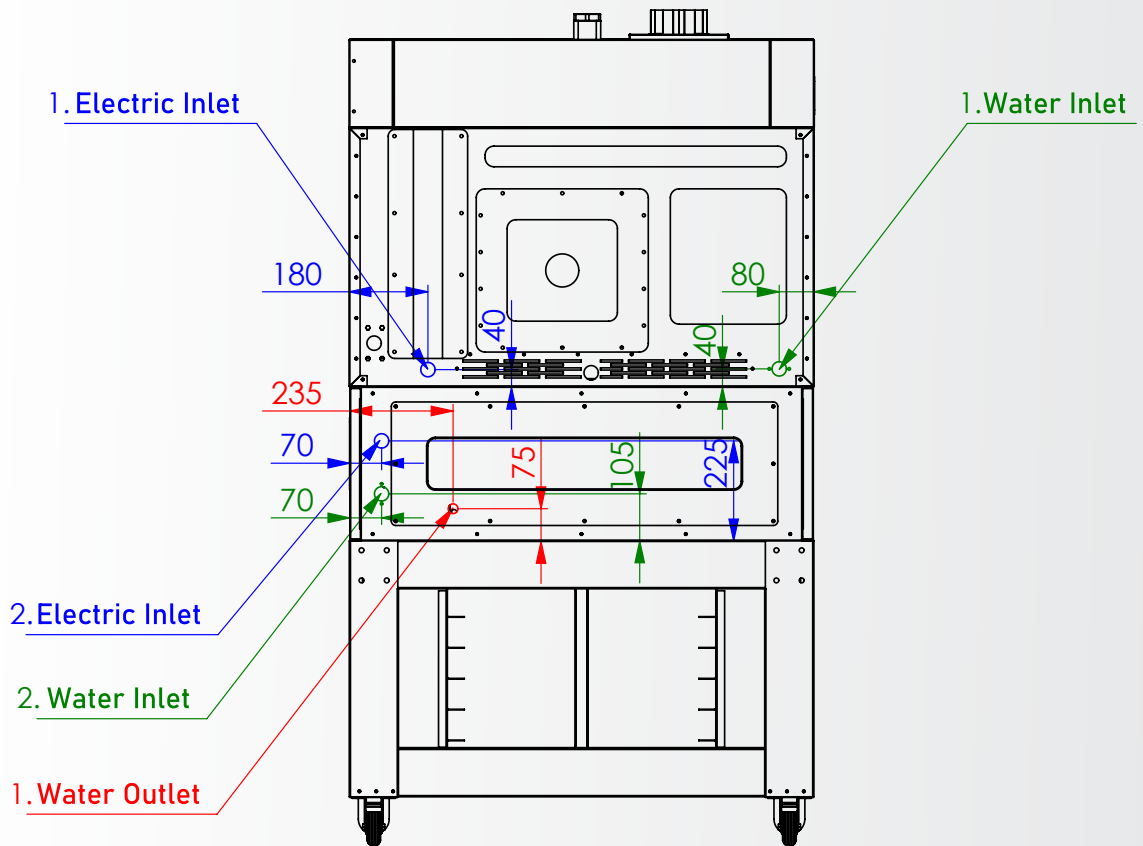

## ELECTRIC INLET

1. TRIPHASES, 9 kW, 13,6 AMPER, 50 HZ
2. TRIPHASES, 9,25 kW, 14 AMPER, 50 HZ

## WATER INLET

1. 3/4" WATER INLET, 3-6 BAR WATER PRESSURE
2. 3/4" WATER INLET, 3-6 BAR WATER PRESSURE

## WATER OUTLET

1. DIAMETER 15 MM

# TRAY AND TROLLEY



COMPATIBLE WITH 400X600 MM TRAY



LOADING CAPACITY FOR ONE TRAY SHOULD NOT EXCEED **3 KG**

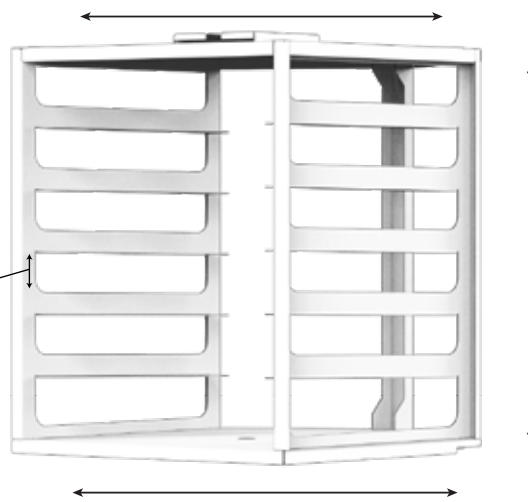
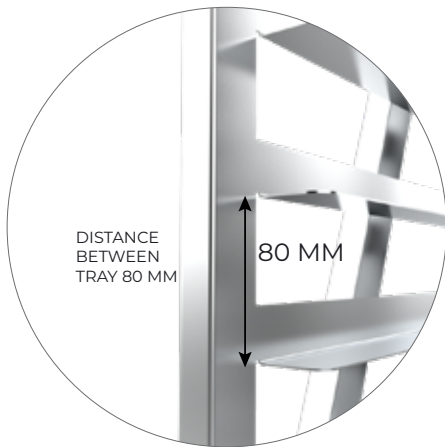
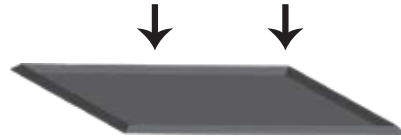

MAXIMUM LOADING CAPACITY OF TROLLEY SHOULD NOT EXCEED **15 KG**

## OPTIONALS

- Black front
- 110 V Electrical system

**THANK YOU**

# inoven

Innovative Oven Technologies

## Artos 5+2

KÜÇÜKBALIKLI MH. ÇAĞLAYAN SK. No: 19  
OSMANGAZI, BURSA / TURKEY  
+90 224 342 63 61 +90 224 342 63 62  
EXPORT@INOVEN.COM.TR  
INFO@INOVEN.COM.TR



Designed and manufactured by  
ISO9001 QUALITY MANAGEMENT STANDARD



ALL INOVEN PRODUCTS ARE DESIGNED AND MANUFACTURED BY AYFA USING  
THE INTERNATIONAL RECOGNISED ISO9001 QUALITY MANAGEMENT SYSTEM  
COVERING DESIGN MANUFACTURE AND FINAL INSPECTION  
WWW.INOVEN.COM.TR